

DMX 模式表版本: V1.1
控制器固件版本: V1.01

DMX Mode Specification Version: V1.1
Controller Firmware Version: V1.01

深圳市神牛摄影器材有限公司

地址: 深圳市宝安区福海街道塘尾社区耀川工业区厂房2栋 电话: 0755-29609320(8062)

传真: 0755-25723423 邮箱: godox@godox.com

GODOX Photo Equipment Co.,Ltd.

Add.: Building 2, Yaochuan Industrial Zone, Tangwei Community, Fuhai Street, Bao'an District, Shenzhen 518103, China

Tel: +86-755-29609320(8062) Fax: +86-755-25723423 E-mail: godox@godox.com

Godox

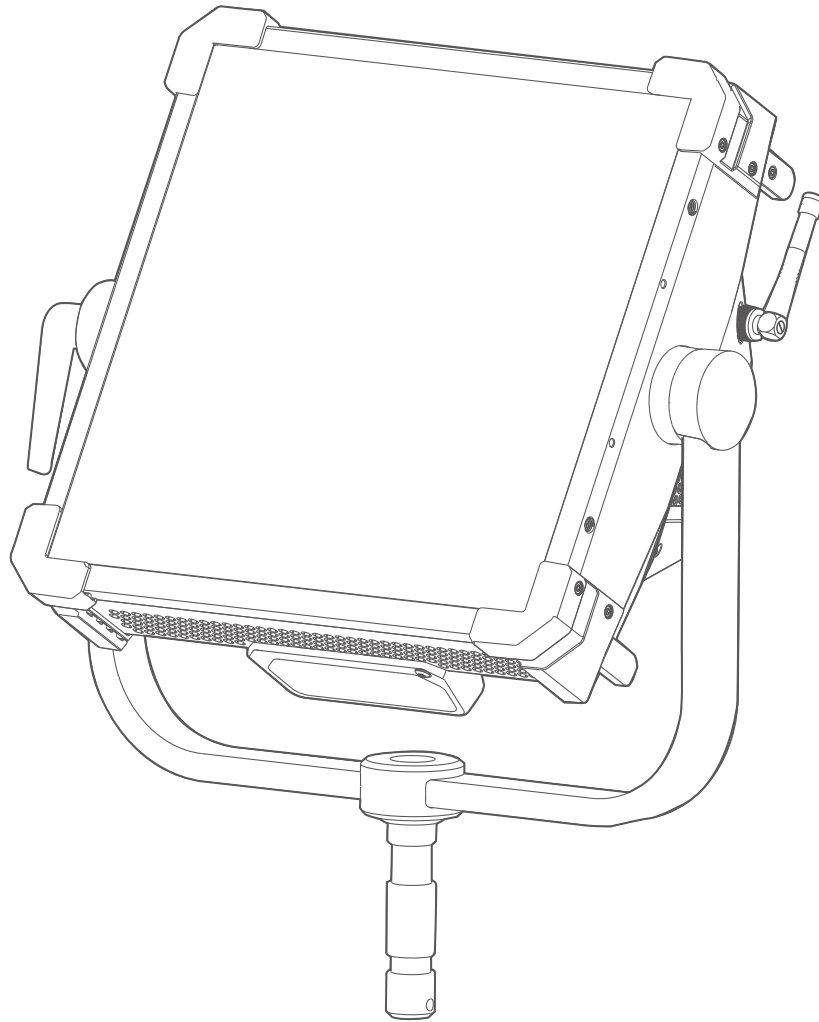

KNOWLED Godox P300R

DMX 模式表
DMX Mode Specification

DMX 模式表如有变更,恕不另行通知,可登录神牛官网 <https://www.godox.com.cn> 查看最新 DMX 模式表。
The DMX Mode Specification may subject to change without notice. Please check the latest electrical version on our official website
<https://www.godox.com>.

DMX控制优先关系：DMX > CRMX > Art-net&sACN

CCT 8Bit模式 & CCT 16Bit模式

DMX 通道		功能	参数名	DMX值 8Bit		实际参数值 8Bit		DMX值 16Bit		实际参数值 16Bit	
8Bit	16Bit			起始值	结束值	起始值	结束值	起始值	结束值	起始值	结束值
1	1-2	CCT	亮度	0	255	0.0%	100.0%	0	65535	0.0%	100.0%
2	3-4		色温	0	255	1800K	10000K	0	65535	1800K	10000K
3	5-6		绿品	0	10	中性 / 无光效		0	04587	中性 / 无光效	
				11	20	全-绿-100%		04588	09830	全-绿-100%	
				21	119	-99%~-1%		09831	30145	-99%~-1%	
				120	145	中性 / 无光效		30146	39976	中性 / 无光效	
				146	244	1%-99%		39977	60292	1%-99%	
	245		255	全+绿100%		60293	65535	全+绿100%			

增强通道：用户打开该功能后 DMX 模式将新增扩展功能通道,具体新增如下表。打开增强通道将占用更多通道,默认该设置为关闭状态。

DMX 通道		功能	参数名	DMX值 8Bit		实际参数值 8Bit		DMX值 16Bit		实际参数值 16Bit	
4	7	CCT	模式	0	9	常规模式		0	9	常规模式	
				10	19	高速模式		10	19	高速模式	
				20	29	低亮模式		20	29	低亮模式	
				30	255	预留		30	255	预留	
5	8		频率	0	9	1		0	9	1	
				10	19	2		10	19	2	
				20	29	3		20	29	3	
				30	39	4		30	39	4	
		40		49	5		40	49	5		
		50		59	6		50	59	6		
		60		69	7		60	69	7		
		70		79	8		70	79	8		
		80		89	9		80	89	9		
		90		99	10		90	99	10		
		100		109	11		100	109	11		
6	9	平滑度	0	9	默认		0	9	默认		
			10	19	平滑		10	19	平滑		
			20	29	关闭		20	29	关闭		
			30	255	预留		30	255	预留		

HSI 8Bit 模式 & HSI 16Bit 模式

DMX 通道		功能	参数名	DMX值 8Bit		实际参数值 8Bit		DMX值 16Bit		实际参数值 16Bit	
8Bit	16Bit			起始值	结束值	起始值	结束值	起始值	结束值	起始值	结束值
1	1-2	HSI	亮度	0	255	0.0%	100.0%	0	65535	0.0%	100.0%
2	3-4		色相	0	255	0	360	0	65535	0	360
3	5-6		饱和度	0	255	0	100	0	65535	0	100

增强通道：用户打开该功能后 DMX 模式将新增扩展功能通道,具体新增如下表。打开增强通道将占用更多通道,默认该设置为关闭状态。

DMX 通道		功能	参数名	DMX值 8Bit		实际参数值 8Bit		DMX值 16Bit		实际参数值 16Bit	
4	7	HSI	模式	0	9	常规模式		0	9	常规模式	
				10	19	高速模式		10	19	高速模式	
				20	29	低亮模式		20	29	低亮模式	
				30	255	预留		30	255	预留	
5	8		频率	0	9	1		0	9	1	
				10	19	2		10	19	2	
				20	29	3		20	29	3	
				30	39	4		30	39	4	
		40		49	5		40	49	5		
		50		59	6		50	59	6		
		60		69	7		60	69	7		
		70		79	8		70	79	8		
		80		89	9		80	89	9		
		90		99	10		90	99	10		
		100		109	11		100	109	11		
6	9	平滑度	0	9	默认		0	9	默认		
			10	19	平滑		10	19	平滑		
			20	29	关闭		20	29	关闭		
			30	255	预留		30	255	预留		

RGBW 8Bit 模式 & RGBW 16Bit 模式

DMX 通道		功能	参数名	DMX值 8Bit		实际参数值 8Bit		DMX值 16Bit		实际参数值 16Bit		
8Bit	16Bit	RGBW	亮度	起始值	结束值	起始值	结束值	起始值	结束值	起始值	结束值	
1	1-2			0	255	0.0%	100.0%	0	65535	0.0%	100.0%	
2	3-4			R (红光)	0	255	0.0%	100.0%	0	65535	0.0%	100.0%
3	4-5			G (绿光)	0	255	0.0%	100.0%	0	65535	0.0%	100.0%
4	6-7			B (蓝光)	0	255	0.0%	100.0%	0	65535	0.0%	100.0%
5	8-9			W (白光)	0	255	0.0%	100.0%	0	65535	0.0%	100.0%

增强通道：用户打开该功能后 DMX 模式将新增扩展功能通道,具体新增如下表。打开增强通道将占用更多通道,默认该设置为关闭状态。

DMX 通道		功能	参数名	DMX值 8Bit		实际参数值 8Bit		DMX值 16Bit		实际参数值 16Bit	
6	10	RGBW	模式	0	9	常规模式		0	9	常规模式	
				10	19	高速模式		10	19	高速模式	
				20	29	低亮模式		20	29	低亮模式	
				30	255	预留		30	255	预留	
7	11	RGBW	频率	0	9	1		0	9	1	
				10	19	2		10	19	2	
				20	29	3		20	29	3	
				30	39	4		30	39	4	
				40	49	5		40	49	5	
				50	59	6		50	59	6	
				60	69	7		60	69	7	
				70	79	8		70	79	8	
				80	89	9		80	89	9	
				90	99	10		90	99	10	
				100	109	11		100	109	11	
				110	255	预留		110	255	预留	
8	12	RGBW	平滑度	0	9	默认		0	9	默认	
				10	19	平滑		10	19	平滑	
				20	29	关闭		20	29	关闭	
				30	255	预留		30	255	预留	

RGBWW 8Bit 模式

DMX 通道		功能	参数名	DMX值 8Bit		实际参数值 8Bit		
8Bit		RGBWW	亮度	起始值	结束值	起始值	结束值	
1				0	255	0.0%	100.0%	
2				R (红光)	0	255	0.0%	100.0%
3				G (绿光)	0	255	0.0%	100.0%
4				B (蓝光)	0	255	0.0%	100.0%
5				W (冷白光)	0	255	0.0%	100.0%
6		W (暖白光)	0	255	0.0%	100.0%		

增强通道：用户打开该功能后 DMX 模式将新增扩展功能通道,具体新增如下表。打开增强通道将占用更多通道,默认该设置为关闭状态。

DMX 通道		功能	参数名	DMX值 8Bit		实际参数值 8Bit	
7	RGBWW	模式	0	9	常规模式		
			10	19	高速模式		
			20	29	低亮模式		
			30	255	预留		
8	RGBWW	频率	0	9	1		
			10	19	2		
			20	29	3		
			30	39	4		
			40	49	5		
			50	59	6		
			60	69	7		
			70	79	8		
			80	89	9		
			90	99	10		
			100	109	11		
			110	255	预留		
9	RGBWW	平滑度	0	9	默认		
			10	19	平滑		
			20	29	关闭		
			30	255	预留		

CCT + HSI 8Bit 模式

DMX 通道	功能	参数名	DMX值 8Bit		实际参数值 8Bit	
			起始值	结束值	起始值	结束值
8Bit	CCT+HSI		0	255	0.0%	100.0%
1		亮度	0	255	1800K	10000K
2		色温	0	255	-100%	100%
3		绿品	0	255	0	100
4		叠化	0	255	0	360
5		色相	0	255	0	100
6		饱和度	0	255		

增强通道：用户打开该功能后 DMX 模式将新增扩展功能通道,具体新增如下表。打开增强通道将占用更多通道,默认该设置为关闭状态。

DMX 通道	功能	参数名	DMX值 8Bit		实际参数值 8Bit
			起始值	结束值	
7		模式	0	9	常规模式
			10	19	高速模式
			20	29	低亮模式
			30	255	预留
8	CCT+HSI	频率	0	9	1
			10	19	2
			20	29	3
			30	39	4
			40	49	5
			50	59	6
			60	69	7
			70	79	8
			80	89	9
			90	99	10
			100	109	11
			110	255	预留
9		平滑度	0	9	默认
			10	19	平滑
			20	29	关闭
			30	255	预留

CCT + RGBW 8Bit 模式

DMX 通道	功能	参数名	DMX值 8Bit		实际参数值 8Bit	
			起始值	结束值	起始值	结束值
8Bit	CCT+RGBW		0	255	0.0%	100.0%
1		亮度	0	255	1800K	10000K
2		色温	0	255	-100%	100%
3		绿品	0	255	0	100
4		叠化	0	255	0.0%	100.0%
5		R (红光)	0	255	0.0%	100.0%
6		G (绿光)	0	255	0.0%	100.0%
7		B (蓝光)	0	255	0.0%	100.0%
8		W (白光)	0	255	0.0%	100.0%

增强通道：用户打开该功能后 DMX 模式将新增扩展功能通道,具体新增如下表。打开增强通道将占用更多通道,默认该设置为关闭状态。

DMX 通道	功能	参数名	DMX值 8Bit		实际参数值 8Bit
			起始值	结束值	
9		模式	0	9	常规模式
			10	19	高速模式
			20	29	低亮模式
			30	255	预留
10	CCT+RGBW	频率	0	9	1
			10	19	2
			20	29	3
			30	39	4
			40	49	5
			50	59	6
			60	69	7
			70	79	8
			80	89	9
			90	99	10
			100	109	11
			110	255	预留
11		平滑度	0	9	默认
			10	19	平滑
			20	29	关闭
			30	255	预留

GEL 8Bit 模式 & GEL 16Bit 模式

DMX 通道		功能	参数名	DMX值 8Bit		实际参数值 8Bit		DMX值 16Bit		实际参数值 16Bit	
8Bit	16Bit			起始值	结束值	起始值	结束值	起始值	结束值	起始值	结束值
1	1-2	GEL	亮度	0	255	0.0%	100.0%	0	65535	0.0%	100.0%
2	3		R-GEL/L-GEL (色片)	0	255	≤128为R-GEL色片	>128为L-GEL色片	0	65535	≤128为R-GEL色片	>128为L-GEL色片
3	4		类型	0	50	R-GEL: COR.	L-GEL: COR.	0	50	R-GEL: COR.	L-GEL: COR.
				51	101	R-GEL: CAL.	L-GEL: COLOR.	51	101	R-GEL: CAL.	L-GEL: COLOR.
				102	152	R-GEL: SPC.	L-GEL: 600	102	152	R-GEL: SPC.	L-GEL: 600
				153	203	R-GEL: CINE.	L-GEL: COS.	153	203	R-GEL: CINE.	L-GEL: COS.
				204	255	L-GEL: 700		204	255	L-GEL: 700	
4	5	色温	0	255	≤128为3200K	>128为5600K	0	65535	≤128为3200K	>128为5600K	
5	6-7	色号	0	255	0	不同类别色片的色号总数 (详细请看下表)	0	65535	0	不同类别色片的色号总数 (详细请看下表)	
6	8	微调色相	0	255	0-10 色相=0; 11-255 色相 (-10--+10)		0	255	0-10 色相=0; 11-255 色相 (-10--+10)		
7	9	微调饱和度	0	255	0-10 饱和度=0; 11-255 饱和度 (-20--+20)		0	255	0-10 饱和度=0; 11-255 饱和度 (-20--+20)		

增强通道: 用户打开该功能后 DMX 模式将新增扩展功能通道, 具体新增如下表。打开增强通道将占用更多通道, 默认该设置为关闭状态。

DMX 通道		功能	参数名	DMX值 8Bit		实际参数值 8Bit		DMX值 16Bit		实际参数值 16Bit	
8	10		模式	0	9	常规模式	0	9	常规模式	0	9
				10	19	高速模式	10	19	高速模式	10	19
				20	29	低亮模式	20	29	低亮模式	20	29
				30	255	预留	30	255	预留	30	255
9	11	GEL	频率	0	9	1	0	9	1	0	9
				10	19	2	10	19	2	10	19
				20	29	3	20	29	3	20	29
				30	39	4	30	39	4	30	39
				40	49	5	40	49	5	40	49
				50	59	6	50	59	6	50	59
				60	69	7	60	69	7	60	69
				70	79	8	70	79	8	70	79
				80	89	9	80	89	9	80	89
				90	99	10	90	99	10	90	99
				100	109	11	100	109	11	100	109
				110	255	预留	110	255	预留	110	255
10	12		平滑度	0	9	默认	0	9	默认	0	9
				10	19	平滑	10	19	平滑	10	19
				20	29	关闭	20	29	关闭	20	29
				30	255	预留	30	255	预留	30	255

R-GEL 色片

DMX通道	COR. (总数33)	
	色纸名称	型号
0-1	Full CTB	3202
2-3	3/4 CTB	3203
4-5	1/2 CTB	3204
6-7	1/3 CTB	3206
8-9	1/4 CTB	3208
10-11	1/8 CTB	3216
12-13	Double	3220
14-15	CTB Full	3407
16-17	CTO 3/4 CTO	3411
18-19	1/2 CTO	3408
20-21	1/4 CTO	3409
22-23	1/8 CTO	3410
24-25	Double CTO	3420
26-27	Full CTS	3441
28-29	1/2 CTS	3442
30-31	1/4 CTS	3443
32-33	1/8 CTS	3444
34-35	Full Plusgreen	3304
36-37	1/2 Plusgreen	3315
38-39	1/4 Plusgreen	3316
40-41	1/8 Plusgreen	3317
42-43	FullMinusgreen	3308
44-45	3/4 Minusgrn	3309
46-47	1/2 Minusgreen	3313
48-49	1/4 Minusgreen	3314
50-51	1/8 Minusgreen	3318
52-53	Fluorofilter	3310
54-55	Industrial Vapor	3150
56-57	Urban Vapor	3152
58-59	Tough Y-1	3107
60-61	Tough MT 54	3134
62-63	Tough MTY	3106
64-65	Tough MT2	3102

DMX通道	CAL. (总数33)	
	色纸名称	型号
0-1	15 Blue	4215
2-3	30 Blue	4230
4-5	60 Blue	4260
6-7	90 Blue	4290
8-9	7 Cyan	4307
10-11	15 Cyan	4315
12-13	30 Cyan	4330
14-15	60 Cyan	4360
16-17	90 Cyan	4390
18-19	15 Green	4415
20-21	30 Green	4430
22-23	60 Green	4460
24-25	90 Green	4490
26-27	15 Yellow	4515
28-29	30 Yellow	4530
30-31	60 Yellow	4560
32-33	90 Yellow	4590
34-35	15 Red	4615
36-37	30 Red	4630
38-39	60 Red	4660
40-41	90 Red	4690
42-43	15 Magenta	4715
44-45	30 Magenta	4730
46-47	60 Magenta	4760
48-49	90 Magenta	4790
50-51	15 Pink	4815
52-53	30 Pink	4830
54-55	60 Pink	4860
56-57	90 Pink	4890
58-59	15 Lavender	4915
60-61	30 Lavender	4930
62-63	60 Lavender	4960
64-65	90 Lavender	4990

DMX通道	SPC. (总数10)	
	色纸名称	型号
0-1	VS Red	2001
2-3	VS Orange	2002
4-5	VS Yellow	2003
6-7	VS Green	2004
8-9	VS Cyan	2005
10-11	VS Azure	2006
12-13	VS Blue	2007
14-15	VS Indigo	2008
16-17	VS Violet	2009
18-19	VS Magenta	2010

DMX通道	CINE. (总数46)	
	色纸名称	型号
0-1	Bastard Amber	2
2-3	Pale Bastard Amber	302
4-5	No Color Straw	6
6-7	Pale Gold	8
8-9	Daffodil	310
10-11	Straw	12
12-13	Light Amber	16
14-15	Gallo Gold	316
16-17	Light Flame	17
18-19	Flame	18
20-21	Mayan Sun	318
22-23	Golden Amber	21
24-25	Soft Golden Amber	321
26-27	Orange	23
28-29	Henna Sky	325
30-31	Light Red	26
32-33	No Color Pink	33
34-35	Blush Pink	333
36-37	Flesh Pink	34
38-39	Pale Rose Pink	37
40-41	Salmon	41
42-43	Deep Salmon	42
44-45	Middle Rose	44
46-47	Light Rose Purple	47
48-49	Surprise Pink	51
50-51	No Color Blue	60
52-53	Clearwater	360
54-55	Booster Blue	62
56-57	Tipton Blue	362
58-59	Blue Bell	364
60-61	Daylight Blue	65
62-63	Tharon Delft Blue	365
64-65	Cerulean Blue	375
66-67	Bermuda Blue	376
68-69	Green Blue	77
70-71	Alice Blue	378
72-73	Primary Blue	80
74-75	Baldassari Blue	381
76-77	Medium Blue	83
78-79	Pale Yellow Green	87
80-81	Light Green	88
82-83	Moss Green	89
84-85	Primary Green	91
86-87	Turquoise	92
88-89	Blue Green	93
90-91	Chocolate	99

L-GEL 色片

DMX通道	COR. (总数39)	
	色纸名称	型号
0-1	Double CTB	200
2-3	Full CTB	201
4-5	3/4 CTB	281
6-7	1/2 CTB	202
8-9	1/4 CTB	203
10-11	1/8 CTB	218
12-13	Double CTO	287
14-15	CTO Full	204
16-17	CTO 3/4 CTO	285
18-19	1/2 CTO	205
20-21	1/4 CTO	206
22-23	1/8 CTO	223
24-25	1 1/2 CTB	283
26-27	1 1/2 CTO	286
28-29	Full CTS	441
30-31	1/2 CTS	442
32-33	1/4 CTS	443
34-35	1/8 CTS	444
36-37	Full CTO + .3 ND	207
38-39	Full CTO + .6 ND	208
40-41	L.C.T. Yellow (Y1)	212
42-43	White Flame Green	213
44-45	LEE Fluorescent Green	219
46-47	Super Correction L.C.T.	230
48-49	Yellow Super Correction	232
50-51	W.F. Green	236
52-53	H.M.I. (to Tungsten)	237
54-55	C.I.D. (to Tungsten)	238
56-57	C.S.I. (to Tungsten)	241
58-59	LEE Fluorescent 5700 Kelvin	242
60-61	LEE Fluorescent 4300 Kelvin	243
62-63	LEE Fluorescent 3600 Kelvin	244
64-65	LEE Plus Green	245
66-67	1/2 Plus Green	246
68-69	1/4 Plus Green	278
70-71	1/8 Plus Green	247
72-73	LEE Minus Green	248
74-75	1/2 Minus Green	249
76-77	1/4 Minus Green	279

DMX通道	COLOR. (总数89)	
	色纸名称	型号
0-1	Rose Pink	2
2-3	Lavender Tint	3
4-5	Medium Bastard Amber	4
6-7	Pale Yellow	7
8-9	Dark Salmon	8
10-11	Pale Amber Gold	9
12-13	Medium Yellow	10
14-15	Straw Tint	13
16-17	Surprise Peach	17
18-19	Fire	19
20-21	Medium Amber	20
22-23	Gold Amber	21
24-25	Dark Amber	22
26-27	Scarlet	24
28-29	Sunset Red	25
30-31	Bright Red	26
32-33	Light Pink	35
34-35	Medium Pink	36
36-37	Dark Magenta	46
38-39	Rose Purple	48
40-41	Light Lavender	52
42-43	Paler Lavender	53
44-45	Lavender	58
46-47	Mist Blue	61
48-49	Pale Blue	63
50-51	Sky Blue	68
52-53	Evening Blue	75
54-55	Just Blue	79
56-57	Deeper Blue	85
58-59	Lime Green	88
60-61	Moss Green	89
62-63	Dark Yellow Green	90
64-65	Spring Yellow	100
66-67	Yellow	101
68-69	Light Amber	102
70-71	Straw	103
72-73	Deep Amber	104
74-75	Primary Red	106
76-77	Light Rose	107
78-79	English Rose	108
80-81	Light Salmon	109
82-83	Middle Rose	110
84-85	Dark Pink	111
86-87	Magenta	113
88-89	Peacock Blue	115
90-91	Steel Blue	117
92-93	Light Blue	118
94-95	Deep Blue	120
96-97	LEE Green	121
98-99	Fern Green	122
100-101	Dark Green	124
102-103	Smokey Pink	127
104-105	Bright Pink	128
106-107	Marine Blue	131
108-109	Golden Amber	134
110-111	Deep Golden Amber	135
112-113	Pale Lavender	136
114-115	Special Lavender	137
116-117	Pale Green	138
118-119	Summer Blue	140
120-121	Pale Violet	142
122-123	Pale Navy Blue	143
124-125	No Color Blue	144
126-127	Apricot	147
128-129	Bright Rose	148
130-131	Gold Tint	151
132-133	Pale Gold	152
134-135	Pale Salmon	153
136-137	Pale Rose	154
138-139	Chocolate	156
140-141	Pink	157
142-143	No Color Straw	159
144-145	Slate Blue	161
146-147	Bastard Amber	162
148-149	Flame Red	164
150-151	Daylight Blue	165
152-153	Lilac Tint	169
154-155	Deep Lavender	170
156-157	Dark Steel Blue	174
158-159	Loving Amber	176
160-161	Dark Lavender	180
162-163	Light Red	182
164-165	Flesh Pink	192
166-167	Surprise Pink	194
168-169	Zenith Blue	195
170-171	True Blue	196
172-173	Alice Blue	197
174-175	Palace Blue	198
176-177	Regal Blue	199

DMX通道	600 (总数9)	
	色纸名称	型号
0-1	Arctic White	600
2-3	Silver	601
4-5	Platinum	602
6-7	Moonlight White	603
8-9	Full CT 85	604
10-11	Industry Sodium	650
12-13	HI Sodium	651
14-15	Urban Sodium	652
16-17	LO Sodium	653

DMX通道	COS. (总数18)	
	色纸名称	型号
0-1	Cosmetic Peach	184
2-3	Cosmetic Silver Rose	186
4-5	Cosmetic Rouge	187
6-7	Cosmetic Highlight	188
8-9	Cosmetic Silver Moss	189
10-11	Cosmetic Aqua Blue	191
12-13	Lily Frost	705
14-15	Shanklin Frost	717
16-17	Half Shanklin Frost	718
18-19	Durham Daylight Frost	720
20-21	Hampshire Rose	749
22-23	Durham Frost	750
24-25	Soft Amber Key 1	774
26-27	Soft Amber Key 2	775
28-29	Moroccan Frost	791
30-31	Blue Diffusion	217
32-33	Blue Frost	221
34-35	Daylight Blue frost	224

DMX通道	700 (总数41)	
	色纸名称	型号
0-1	Perfect Lavender	700
2-3	Provence	701
4-5	Special Pale Lavender	702
6-7	Cold Lavender	703
8-9	Lily	704
10-11	King Fals Lavender	706
12-13	Cool Lavender	708
14-15	Electric Lilac	709
16-17	Spir Special Blue	710
18-19	Cold Blue	711
20-21	Bedford Blue	712
22-23	Elysian Blue	714
24-25	Cabana Blue	715
26-27	Mikkel Blue	716
28-29	Colour Wash Blue	719
30-31	Berry Blue	721
32-33	Virgin Blue	723
34-35	Ocean Blue	724
36-37	Old Steel Blue	725
38-39	Steel Green	728
40-41	Liberty Green	730
42-43	Dirty Ice	731
44-45	Damp Squib	733
46-47	JAS Green	738
48-49	Bram Brown	742
50-51	Dirty White	744
52-53	Brown	746
54-55	Easy White	747
56-57	Seedy Pink	748
58-59	Wheat	763
60-61	Sun Colour Straw	764
62-63	LEE Yellow	765
64-65	Cardbox Amber	773
66-67	Nectarine	776
68-69	Millenium Gold	778
70-71	Bastard Pink	779
72-73	Terry Red	781
74-75	Blood Red	789
76-77	Moroccan Pink	790
78-79	Pretty n'Pink	794
80-81	Magical Magenta	795

X-Y 16Bit 模式

DMX 通道	功能	参数名	DMX值 16Bit		实际参数值 16Bit	
16Bit	X-Y		起始值	结束值	起始值	结束值
1-2		亮度	0	65535	0.0%	100.0%
3-4		X	0	65535	0	0.85
5-6		Y	0	65535	0	0.85

增强通道：用户打开该功能后 DMX 模式将新增扩展功能通道，具体新增如下表。打开增强通道将占用更多通道，默认该设置为关闭状态。

DMX 通道	功能	参数名	DMX值 16Bit		实际参数值 16Bit
7	X-Y	模式	0	9	常规模式
			10	19	高速模式
			20	29	低亮模式
			30	255	预留
8		频率	0	9	1
			10	19	2
			20	29	3
			30	39	4
			40	49	5
			50	59	6
			60	69	7
			70	79	8
			80	89	9
	90		99	10	
	100		109	11	
9	平滑度	110	255	预留	
		0	9	默认	
		10	19	平滑	
		20	29	关闭	
			30	255	预留

CCT + RGBW Engine 8Bit 模式

DMX 通道	功能	参数名	DMX值 8 Bit		实际参数值 8Bit	
8Bit	CCT+RGBW Engine 1		起始值	结束值	起始值	结束值
1		亮度	0	255	0.0%	100.0%
2		色温	0	255	1800K	10000K
3		绿品	0	255	-100%	100%
4		蓝品	0	255	0	100
5		R	0	255	0.0%	100.0%
6		G	0	255	0.0%	100.0%
7		B	0	255	0.0%	100.0%
8		W	0	255	0.0%	100.0%
9	CCT+RGBW Engine 2	亮度	0	255	0.0%	100.0%
10		色温	0	255	1800K	10000K
11		绿品	0	255	-100%	100%
12		蓝品	0	255	0	100
13		R	0	255	0.0%	100.0%
14		G	0	255	0.0%	100.0%
15		B	0	255	0.0%	100.0%
16		W	0	255	0.0%	100.0%
17	CCT+RGBW Engine 3	亮度	0	255	0.0%	100.0%
18		色温	0	255	1800K	10000K
19		绿品	0	255	-100%	100%
20		蓝品	0	255	0	100
21		R	0	255	0.0%	100.0%
22		G	0	255	0.0%	100.0%
23		B	0	255	0.0%	100.0%
24	W	0	255	0.0%	100.0%	
25	CCT+RGBW Engine 4	亮度	0	255	0.0%	100.0%
26		色温	0	255	1800K	10000K
27		绿品	0	255	-100%	100%
28		蓝品	0	255	0	100
29		R	0	255	0.0%	100.0%
30		G	0	255	0.0%	100.0%
31		B	0	255	0.0%	100.0%
32		W	0	255	0.0%	100.0%

增强通道：用户打开该功能后 DMX 模式将新增扩展功能通道，具体新增如下表。打开增强通道将占用更多通道，默认该设置为关闭状态。

DMX 通道	功能	参数名	DMX值 8Bit		实际参数值 8Bit
33		模式	0	9	常规模式
			10	19	高速模式
			20	29	低亮模式
			30	255	预留
34	CCT+RGBW Engine	频率	0	9	1
			10	19	2
			20	29	3
			30	39	4
			40	49	5
			50	59	6
			60	69	7
			70	79	8
			80	89	9
			90	99	10
			100	109	11
			110	255	预留
35		平滑度	0	9	默认
			10	19	平滑
			20	29	关闭
			30	255	预留

HSI Engine 8Bit 模式

DMX 通道	功能	参数名	DMX值 8 Bit		实际参数值 8Bit	
			起始值	结束值	起始值	结束值
8Bit	HSI Engine 1	亮度	0	255	0.0%	100.0%
1		色相	0	255	0	360
2		饱和度	0	255	0	100
3	HSI Engine 2	亮度	0	255	0.0%	100.0%
4		色相	0	255	0	360
5		饱和度	0	255	0	100
6	HSI Engine 3	亮度	0	255	0.0%	100.0%
7		色相	0	255	0	360
8		饱和度	0	255	0	100
9	HSI Engine 4	亮度	0	255	0.0%	100.0%
10		色相	0	255	0	360
11		饱和度	0	255	0	100
12						

增强通道：用户打开该功能后 DMX 模式将新增扩展功能通道,具体新增如下表。打开增强通道将占用更多通道,默认该设置为关闭状态。

DMX 通道	功能	参数名	DMX值 8Bit		实际参数值 8Bit
			起始值	结束值	
13		模式	0	9	常规模式
			10	19	高速模式
			20	29	低亮模式
			30	255	预留
14	HSI Engine	频率	0	9	1
			10	19	2
			20	29	3
			30	39	4
			40	49	5
			50	59	6
			60	69	7
			70	79	8
			80	89	9
			90	99	10
			100	109	11
			110	255	预留
15		平滑度	0	9	默认
			10	19	平滑
			20	29	关闭
			30	255	预留

FX 8Bit 模式 & FX 16Bit 模式

DMX 通道		功能	参数名	DMX值 8 Bit		实际参数值 8Bit		DMX值 16Bit		实际参数值 16Bit		
8Bit	16Bit			起始值	结束值	起始值	结束值	起始值	结束值	起始值	结束值	
1	1-2	光效类型	光效种类	亮度	0	255	0.0%	100.0%	0	65535	0.0%	100.0%
2	3			0	9	光效关闭		0	9	光效关闭		
				10	19	闪光灯		10	19	闪光灯		
				20	29	雷闪电		20	29	雷闪电		
				30	39	多云		30	39	多云		
				40	49	坏灯泡		40	49	坏灯泡		
				50	59	TV		50	59	TV		
				60	69	蜡烛		60	69	蜡烛		
				70	79	火		70	79	火		
				80	89	烟花		80	89	烟花		
				90	99	爆炸		90	99	爆炸		
				100	109	焊接		100	109	焊接		
				110	119	警车		110	119	警车		
				120	129	SOS		120	129	SOS		
				130	139	彩光循环		140	139	彩光循环		
				140	149	派对		150	149	派对		
				150	159	彩虹		160	159	彩虹		
		160	169	像素蜡烛		170	169	像素蜡烛				
		170	179	像素火		180	179	像素火				
3	4	闪光灯	类型	0	255	CCT (0-127)	HSI (128-255)	0	255	CCT (0-127)	HSI (128-255)	
4	5-6		色温/色相	0	255	1800K/0	10000K/360	0	65535	1800K/0	10000K/360	
5	7-8		速度	0	255	0	100	0	65535	0	100	
6	9-10		模式	0	255	0闪光灯	1镁光灯	0	255	0闪光灯	1镁光灯	
3	4-5	雷闪电	色温	0	255	2800K	6500K	0	65535	2800K	6500K	
4	6-7		频率	0	255	0	20	0	65535	0	20	
5	8-9		次数	0	255	0	10	0	65535	0	10	
3	4-5	多云	亮暗比例	0	255	10%	90%	0	65535	10%	90%	
4	6-7		速度	0	255	0	100	0	65535	0	100	
3	4-5	坏灯泡	类型	0	255	CCT (0-127)	HSI (128-255)	0	255	CCT (0-127)	HSI (128-255)	
4	5-6		色温/色相	0	255	1800K/0	10000K/360	0	65535	1800K/0	10000K/360	
5	7-8		速度	0	255	0	100	0	65535	0	100	
3	4-5	TV	类型	0	255	CCT (0-127)	HSI (128-255)	0	255	CCT (0-127)	HSI (128-255)	
4	5-6		速度	0	255	0	100	0	65535	0	100	
3	4-5	蜡烛	速度	0	255	0	100	0	65535	0	100	
3	4-5	火	速度	0	255	0	100	0	65535	0	100	
3	4-5	烟花	速度	0	255	0	100	0	65535	0	100	
4	6-7		余烬	0	255	0	100	0	65535	0	100	
3	4-5		爆炸	类型	0	255	CCT (0-127)	HS (128-255)	0	255	CCT (0-127)	HS (128-255)
4	6-7	色温/色相		0	255	1800K/0	10000K/360	0	65535	1800K/0	10000K/360	
5	8-9	速度		0	255	0	100	0	65535	0	100	
6	10-11	余烬		0	255	0	100	0	65535	0	100	
3	4-5	焊接	类型	0	255	CCT (0-127)	HSI (128-255)	0	255	CCT (0-127)	HSI (128-255)	
4	6-7		色温/色相	0	255	1800K/0	10000K/360	0	65535	1800K/0	10000K/360	
5	8-9		速度	0	255	0	100	0	65535	0	100	
3	4-5	SOS	类型	0	255	CCT (0-127)	HSI (128-255)	0	255	CCT (0-127)	HSI (128-255)	
4	6-7		色温/色相	0	255	1800K/0	10000K/360	0	65535	1800K/0	10000K/360	
3	4	警车	颜色	0	255	0	7	0	255	0	7	
4	5		模式	0	255	0	4	0	255	0	4	
3	4-5	彩光循环	饱和度	0	255	0	100	0	65535	0	100	
4	6		速度	0	255	1	100	0	65535	1	100	
3	4-5	派对	饱和度	0	255	0	100	0	65535	0	100	
4	6		速度	0	255	1	100	0	65535	1	100	
3	4	像素蜡烛	色调	0-84		偏暖		0-84		偏暖		
				85-169		中性		85-169		中性		
				170-255		偏冷		170-255		偏冷		
4	5-6	像素火	色调	0	255	1	100	0	65535	1	100	
3	4			0-84		偏暖		0-84		偏暖		
				85-169		中性		85-169		中性		
				170-255		偏冷		170-255		偏冷		
4	6-7	速度	0	255	1	100	0	65535	1	100		

增强通道：用户打开该功能后 DMX 模式将新增扩展功能通道，具体新增如下表。打开增强通道将占用更多通道，默认该设置为关闭状态。

DMX 通道		参数名	DMX值 8Bit		实际参数值 8Bit	DMX值 16Bit		实际参数值 16Bit
7	12	模式	0	9	常规模式	0	9	常规模式
			10	19	高速模式	10	19	高速模式
			20	29	低亮模式	20	29	低亮模式
			30	255	预留	30	255	预留
8	13	频率	0	9	1	0	9	1
			10	19	2	10	19	2
			20	29	3	20	29	3
			30	39	4	30	39	4
			40	49	5	40	49	5
			50	59	6	50	59	6
			60	69	7	60	69	7
			70	79	8	70	79	8
			80	89	9	80	89	9
			90	99	10	90	99	10
			100	109	11	100	109	11
						110	255	预留
9	14	平滑度	0	9	默认	0	9	默认
			10	19	平滑	10	19	平滑
			20	29	关闭	20	29	关闭
			30	255	预留	30	255	预留

计算公式

计算亮度

8Bit

$$\text{DMX 数值} = \frac{\text{亮度数值}}{0.3922}$$

$$\text{亮度数值} = \text{DMX 数值} \times 0.3922$$

16Bit

$$\text{DMX 数值} = \frac{\text{亮度数值}}{0.001526}$$

$$\text{亮度数值} = \text{DMX 数值} \times 0.001526$$

计算色温

8Bit

$$\text{DMX 数值} = \frac{\text{色温数值} - 1800}{32.1568}$$

$$\text{色温数值} = \text{DMX 数值} \times 32.1568 + 1800$$

16Bit

$$\text{DMX 数值} = \frac{\text{色温数值} - 1800}{0.1251}$$

$$\text{色温数值} = \text{DMX 数值} \times 0.1251 + 1800$$

DMX Control Priority: DMX > CRMX > Art-net&sACN

CCT 8Bit Mode & CCT 16Bit Mode

DMX channel		Function	Parameter	DMX value 8Bit		Actual value 8Bit		DMX value 16Bit		Actual value 16Bit			
8Bit	16Bit	CCT	Brightness	Starting	Ending	Starting	Ending	Starting	Ending	Starting	Ending		
1	1-2			0	255	0.0%	100.0%	0	65535	0.0%	100.0%		
2	3-4			GM	CCT	0	255	1800K	10000K	0	65535	1800K	10000K
3	5-6				0	10	Neutral/No Effect		0	04587	Neutral/No Effect		
					11	20	Full Minus Green-100%		04588	09830	Full Minus Green-100%		
					21	119	-99%~-1%		09831	30145	-99%~-1%		
					120	145	Neutral/No Effect		30146	39976	Neutral/No Effect		
					146	244	1%-99%		39977	60292	1%-99%		
		245	255	Full Plus Green 100%		60293	65535	Full Plus Green 100%					

Extend DMX Channels: The DMX mode will add extended channels when this function is turned on, as shown in the following table. Turning on the extend DMX channels will take up more channels, and this setting is off by default.

DMX channel		Function	Parameter	DMX value 8Bit		Actual value 8Bit		DMX value 16Bit		Actual value 16Bit	
4	7	CCT	Mode	0	9	Normal		0	9	Normal	
				10	19	Highspeed		10	19	Highspeed	
				20	29	Low End		20	29	Low End	
				30	255	Preset		30	255	Preset	
5	8	CCT	Frequency	0	9	1		0	9	1	
				10	19	2		10	19	2	
				20	29	3		20	29	3	
				30	39	4		30	39	4	
				40	49	5		40	49	5	
				50	59	6		50	59	6	
				60	69	7		60	69	7	
				70	79	8		70	79	8	
				80	89	9		80	89	9	
				90	99	10		90	99	10	
				100	109	11		100	109	11	
6	9	CCT	Smoothing	0	9	Default		0	9	Default	
				10	19	Smooth		10	19	Smooth	
				20	29	Off		20	29	Off	
				30	255	Preset		30	255	Preset	

HSI 8Bit Mode & HSI 16Bit Mode

DMX channel		Function	Parameter	DMX value 8Bit		Actual value 8Bit		DMX value 16Bit		Actual value 16Bit			
8Bit	16Bit	HSI	Brightness	Starting	Ending	Starting	Ending	Starting	Ending	Starting	Ending		
1	1-2			0	255	0.0%	100.0%	0	65535	0.0%	100.0%		
2	3-4			Saturation	Hue	0	255	0	360	0	65535	0	360
3	5-6				0	255	0	100	0	65535	0	100	

Extend DMX Channels: The DMX mode will add extended channels when this function is turned on, as shown in the following table. Turning on the extend DMX channels will take up more channels, and this setting is off by default.

DMX channel		Function	Parameter	DMX value 8Bit		Actual value 8Bit		DMX value 16Bit		Actual value 16Bit	
4	7	HSI	Mode	0	9	Normal		0	9	Normal	
				10	19	Highspeed		10	19	Highspeed	
				20	29	Low End		20	29	Low End	
				30	255	Preset		30	255	Preset	
5	8	HSI	Frequency	0	9	1		0	9	1	
				10	19	2		10	19	2	
				20	29	3		20	29	3	
				30	39	4		30	39	4	
				40	49	5		40	49	5	
				50	59	6		50	59	6	
				60	69	7		60	69	7	
				70	79	8		70	79	8	
				80	89	9		80	89	9	
				90	99	10		90	99	10	
				100	109	11		100	109	11	
6	9	HSI	Smoothing	0	9	Default		0	9	Default	
				10	19	Smooth		10	19	Smooth	
				20	29	Off		20	29	Off	
				30	255	Preset		30	255	Preset	

RGBW 8Bit Mode & RGBW 16Bit Mode

DMX channel		Function	Parameter	DMX value 8Bit		Actual value 8Bit		DMX value 16Bit		Actual value 16Bit		
8Bit	16Bit	RGBW	Brightness	Starting	Ending	Starting	Ending	Starting	Ending	Starting	Ending	
1	1-2			0	255	0.0%	100.0%	0	65535	0.0%	100.0%	
2	3-4			R (Red light)	0	255	0.0%	100.0%	0	65535	0.0%	100.0%
3	4-5			G(Green light)	0	255	0.0%	100.0%	0	65535	0.0%	100.0%
4	6-7			B(Blue light)	0	255	0.0%	100.0%	0	65535	0.0%	100.0%
5	8-9			W(White light)	0	255	0.0%	100.0%	0	65535	0.0%	100.0%

Extend DMX Channels: The DMX mode will add extended channels when this function is turned on, as shown in the following table. Turning on the extend DMX channels will take up more channels, and this setting is off by default.

DMX channel		Function	Parameter	DMX value 8Bit		Actual value 8Bit		DMX value 16Bit		Actual value 16Bit	
6	10	RGBW	Mode	0	9	Normal		0	9	Normal	
				10	19	Highspeed		10	19	Highspeed	
				20	29	Low End		20	29	Low End	
				30	255	Preset		30	255	Preset	
7	11		Frequency	0	9	1		0	9	1	
				10	19	2		10	19	2	
				20	29	3		20	29	3	
				30	39	4		30	39	4	
				40	49	5		40	49	5	
				50	59	6		50	59	6	
				60	69	7		60	69	7	
				70	79	8		70	79	8	
		80		89	9		80	89	9		
		90		99	10		90	99	10		
		100		109	11		100	109	11		
8	12	Smoothing	0	9	Default		0	9	Default		
			10	19	Smooth		10	19	Smooth		
			20	29	Off		20	29	Off		
			30	255	Preset		30	255	Preset		

RGBWW 8Bit Mode

DMX channel		Function	Parameter	DMX value 8Bit		Actual value 8Bit		
8Bit	16Bit	RGBWW	Brightness	Starting	Ending	Starting	Ending	
1	1-2			0	255	0.0%	100.0%	
2	3-4			R(Red light)	0	255	0.0%	100.0%
3	4-5			G(Green light)	0	255	0.0%	100.0%
4	6-7			B(Blue light)	0	255	0.0%	100.0%
5	8-9			W(Cool white light)	0	255	0.0%	100.0%
6	10-11			W(Warm white light)	0	255	0.0%	100.0%

Extend DMX Channels: The DMX mode will add extended channels when this function is turned on, as shown in the following table. Turning on the extend DMX channels will take up more channels, and this setting is off by default.

DMX channel		Function	Parameter	DMX value 8Bit		Actual value 8Bit	
7		RGBWW	Mode	0	9	Normal	
				10	19	Highspeed	
				20	29	Low End	
				30	255	Preset	
8			Frequency	0	9	1	
				10	19	2	
				20	29	3	
				30	39	4	
				40	49	5	
				50	59	6	
				60	69	7	
				70	79	8	
		80		89	9		
		90		99	10		
		100		109	11		
9		Smoothing	0	9	Default		
			10	19	Smooth		
			20	29	Off		
			30	255	Preset		

CCT + HSI 8Bit Mode

DMX channel	Function	Parameter	DMX value 8Bit		Actual value 8Bit	
			Starting	Ending	Starting	Ending
8Bit	CCT+HSI		Starting	Ending	Starting	Ending
1		Brightness	0	255	0.0%	100.0%
2		CCT	0	255	1800K	10000K
3		GM	0	255	-100%	100%
4		Dissolve	0	255	0	100
5		Hue	0	255	0	360
6	Saturation	0	255	0	100	

Extend DMX Channels: The DMX mode will add extended channels when this function is turned on, as shown in the following table. Turning on the extend DMX channels will take up more channels, and this setting is off by default.

DMX channel	Function	Parameter	DMX value 8Bit		Actual value 8Bit
7	CCT+HSI	Mode	0	9	Normal
			10	19	Highspeed
			20	29	Low End
			30	255	Preset
			0	9	1
8		Frequency	10	19	2
			20	29	3
			30	39	4
			40	49	5
			50	59	6
			60	69	7
			70	79	8
			80	89	9
			90	99	10
			100	109	11
9	Smoothing	110	255	Preset	
		0	9	Default	
		10	19	Smooth	
		20	29	Off	
		30	255	Preset	

CCT + RGBW 8Bit Mode

DMX channel	Function	Parameter	DMX value 8Bit		Actual value 8Bit	
			Starting	Ending	Starting	Ending
8Bit	CCT+RGBW		Starting	Ending	Starting	Ending
1		Brightness	0	255	0.0%	100.0%
2		CCT	0	255	1800K	10000K
3		GM	0	255	-100%	100%
4		Dissolve	0	255	0	100
5		R(Red light)	0	255	0.0%	100.0%
6		G(Green light)	0	255	0.0%	100.0%
7		B(Blue light)	0	255	0.0%	100.0%
8	W(White light)	0	255	0.0%	100.0%	

Extend DMX Channels: The DMX mode will add extended channels when this function is turned on, as shown in the following table. Turning on the extend DMX channels will take up more channels, and this setting is off by default.

DMX channel	Function	Parameter	DMX value 8Bit		Actual value 8Bit
9	CCT+RGBW	Mode	0	9	Normal
			10	19	Highspeed
			20	29	Low End
			30	255	Preset
			0	9	1
10		Frequency	10	19	2
			20	29	3
			30	39	4
			40	49	5
			50	59	6
			60	69	7
			70	79	8
			80	89	9
			90	99	10
			100	109	11
11	Smoothing	110	255	Preset	
		0	9	Default	
		10	19	Smooth	
		20	29	Off	
		30	255	Preset	

GEL 8Bit Mode & GEL 16Bit Mode

DMX channel		Function	Parameter	DMX value 8Bit		Actual value 8Bit		DMX value 16Bit		Actual value 16Bit			
8Bit	16Bit			Starting	Ending	Starting	Ending	Starting	Ending	Starting	Ending		
1	1-2	GEL	Brightness	0	255	0.0%	100.0%	0	255	0.0%	100.0%		
2	3		R-GEL/L-GEL	0	255	≤128: R-GEL >128: L-GEL		0	255	≤128: R-GEL >128: L-GEL			
3	4		Type	0	50	R-GEL: COR. L-GEL: COR.		0	50	R-GEL: COR. L-GEL: COR.			
				51	101	R-GEL: CAL. L-GEL: COLOR.		51	101	R-GEL: CAL. L-GEL: COLOR.			
				102	152	R-GEL: SPC. L-GEL: 600		102	152	R-GEL: SPC. L-GEL: 600			
				153	203	R-GEL: CINE. L-GEL: COS.		153	203	R-GEL: CINE. L-GEL: COS.			
				204	255	L-GEL: 700		204	255	L-GEL: 700			
4	5		CCT	0	255	≤128: 3200K >128: 5600K		0	255	≤128: 3200K >128: 5600K			
5	6-7		Color number	0	255	0	Total color numbers for different categories(refer to the table below)		0	255	0	Total color numbers for different categories(refer to the table below)	
6	8		Fine-tune hue	0	255	0-10 Hue=0; 11-255 Hue (-10--+10)		0	255	0-10 Hue=0; 11-255 Hue (-10--+10)			
7	9	Fine-tune saturation	0	255	0-10 Sat=0; 11-255 Sat (-20--+20)		0	255	0-10 Sat=0; 11-255 Sat (-20--+20)				

Extend DMX Channels: The DMX mode will add extended channels when this function is turned on, as shown in the following table. Turning on the extend DMX channels will take up more channels, and this setting is off by default.

DMX channel		Function	Parameter	DMX value 8Bit		Actual value 8Bit		DMX value 16Bit		Actual value 16Bit			
8	10	GEL	Mode	0	9	Normal		0	9	Normal			
					10	19	Highspeed		10	19	Highspeed		
					20	29	Low End		20	29	Low End		
					30	255	Preset		30	255	Preset		
9	11		GEL	Frequency	0	9	1		0	9	1		
						10	19	2		10	19	2	
						20	29	3		20	29	3	
						30	39	4		30	39	4	
						40	49	5		40	49	5	
						50	59	6		50	59	6	
					60	69	7		60	69	7		
					70	79	8		70	79	8		
					80	89	9		80	89	9		
					90	99	10		90	99	10		
			100	109	11		100	109	11				
			110	255	Preset		110	255	Preset				
10	12	GEL	Smoothing	0	9	Default		0	9	Default			
					10	19	Smooth		10	19	Smooth		
					20	29	Off		20	29	Off		
					30	255	Preset		30	255	Preset		

R-GEL

DMX channel	COR. (in total 33)	
	Name	Model
0-1	Full CTB	3202
2-3	3/4 CTB	3203
4-5	1/2 CTB	3204
6-7	1/3 CTB	3206
8-9	1/4 CTB	3208
10-11	1/8 CTB	3216
12-13	Double	3220
14-15	CTB Full	3407
16-17	CTO 3/4 CTO	3411
18-19	1/2 CTO	3408
20-21	1/4 CTO	3409
22-23	1/8 CTO	3410
24-25	Double CTO	3420
26-27	Full CTS	3441
28-29	1/2 CTS	3442
30-31	1/4 CTS	3443
32-33	1/8 CTS	3444
34-35	Full Plusgreen	3304
36-37	1/2 Plusgreen	3315
38-39	1/4 Plusgreen	3316
40-41	1/8 Plusgreen	3317
42-43	FullMinusgreen	3308
44-45	3/4 Minusgrn	3309
46-47	1/2 Minusgreen	3313
48-49	1/4 Minusgreen	3314
50-51	1/8 Minusgreen	3318
52-53	Fluorofilter	3310
54-55	Industrial Vapor	3150
56-57	Urban Vapor	3152
58-59	Tough Y-1	3107
60-61	Tough MT 54	3134
62-63	Tough MTY	3106
64-65	Tough MT2	3102

DMX channel	CAL. (in total 33)	
	Name	Model
0-1	15 Blue	4215
2-3	30 Blue	4230
4-5	60 Blue	4260
6-7	90 Blue	4290
8-9	7 Cyan	4307
10-11	15 Cyan	4315
12-13	30 Cyan	4330
14-15	60 Cyan	4360
16-17	90 Cyan	4390
18-19	15 Green	4415
20-21	30 Green	4430
22-23	60 Green	4460
24-25	90 Green	4490
26-27	15 Yellow	4515
28-29	30 Yellow	4530
30-31	60 Yellow	4560
32-33	90 Yellow	4590
34-35	15 Red	4615
36-37	30 Red	4630
38-39	60 Red	4660
40-41	90 Red	4690
42-43	15 Magenta	4715
44-45	30 Magenta	4730
46-47	60 Magenta	4760
48-49	90 Magenta	4790
50-51	15 Pink	4815
52-53	30 Pink	4830
54-55	60 Pink	4860
56-57	90 Pink	4890
58-59	15 Lavender	4915
60-61	30 Lavender	4930
62-63	60 Lavender	4960
64-65	90 Lavender	4990

DMX channel	SPC. (in total 10)	
	Name	Model
0-1	VS Red	2001
2-3	VS Orange	2002
4-5	VS Yellow	2003
6-7	VS Green	2004
8-9	VS Cyan	2005
10-11	VS Azure	2006
12-13	VS Blue	2007
14-15	VS Indigo	2008
16-17	VS Violet	2009
18-19	VS Magenta	2010

DMX channel	CINE. (in total 46)	
	Name	Model
0-1	Bastard Amber	2
2-3	Pale Bastard Amber	302
4-5	No Color Straw	6
6-7	Pale Gold	8
8-9	Daffodil	310
10-11	Straw	12
12-13	Light Amber	16
14-15	Gallo Gold	316
16-17	Light Flame	17
18-19	Flame	18
20-21	Mayan Sun	318
22-23	Golden Amber	21
24-25	Soft Golden Amber	321
26-27	Orange	23
28-29	Henna Sky	325
30-31	Light Red	26
32-33	No Color Pink	33
34-35	Blush Pink	333
36-37	Flesh Pink	34
38-39	Pale Rose Pink	37
40-41	Salmon	41
42-43	Deep Salmon	42
44-45	Middle Rose	44
46-47	Light Rose Purple	47
48-49	Surprise Pink	51
50-51	No Color Blue	60
52-53	Clearwater	360
54-55	Booster Blue	62
56-57	Tipton Blue	362
58-59	Blue Bell	364
60-61	Daylight Blue	65
62-63	Tharon Delft Blue	365
64-65	Cerulean Blue	375
66-67	Bermuda Blue	376
68-69	Green Blue	77
70-71	Alice Blue	378
72-73	Primary Blue	80
74-75	Baldassari Blue	381
76-77	Medium Blue	83
78-79	Pale Yellow Green	87
80-81	Light Green	88
82-83	Moss Green	89
84-85	Primary Green	91
86-87	Turquoise	92
88-89	Blue Green	93
90-91	Chocolate	99

L-GEL

DMX channel	COR. (in total 39)	
	Name	Model
0-1	Double CTB	200
2-3	Full CTB	201
4-5	3/4 CTB	201
6-7	1/2 CTB	202
8-9	1/4 CTB	203
10-11	1/8 CTB	218
12-13	Double CTO	287
14-15	CTO Full	204
16-17	CTO 3/4 CTO	285
18-19	1/2 CTO	205
20-21	1/4 CTO	206
22-23	1/8 CTO	223
24-25	1 1/2 CTB	283
26-27	1 1/2 CTO	286
28-29	Full CTS	441
30-31	1/2 CTS	442
32-33	1/4 CTS	443
34-35	1/8 CTS	444
36-37	Full CTO + .3 ND	207
38-39	Full CTO + .6 ND	208
40-41	L.C.T. Yellow (Y1)	212
42-43	White Flame Green	213
44-45	LEE Fluorescent Green	219
46-47	Super Correction L.C.T.	230
48-49	Yellow Super Correction	232
50-51	W.F. Green	236
52-53	H.M.I. (to Tungsten)	237
54-55	C.I.D. (to Tungsten)	238
56-57	C.S.I. (to Tungsten)	241
58-59	LEE Fluorescent 5700 Kelvin	242
60-61	LEE Fluorescent 4300 Kelvin	243
62-63	LEE Fluorescent 3600 Kelvin	244
64-65	LEE Plus Green	245
66-67	1/2 Plus Green	246
68-69	1/4 Plus Green	278
70-71	1/8 Plus Green	247
72-73	LEE Minus Green	248
74-75	1/2 Minus Green	249
76-77	1/4 Minus Green	279

DMX channel	COLOR. (in total 89)	
	Name	Model
0-1	Rose Pink	2
2-3	Lavender Tint	3
4-5	Medium Bastard Amber	4
6-7	Pale Yellow	7
8-9	Dark Salmon	8
10-11	Pale Amber Gold	9
12-13	Medium Yellow	10
14-15	Straw Tint	13
16-17	Surprise Peach	17
18-19	Fire	19
20-21	Medium Amber	20
22-23	Gold Amber	21
24-25	Dark Amber	22
26-27	Scarlet	24
28-29	Sunset Red	25
30-31	Bright Red	26
32-33	Light Pink	35
34-35	Medium Pink	36
36-37	Dark Magenta	46
38-39	Rose Purple	48
40-41	Light Lavender	52
42-43	Paler Lavender	53
44-45	Lavender	58
46-47	Mist Blue	61
48-49	Pale Blue	63
50-51	Sky Blue	68
52-53	Evening Blue	75
54-55	Just Blue	79
56-57	Deeper Blue	85
58-59	Lime Green	88
60-61	Moss Green	89
62-63	Dark Yellow Green	90
64-65	Spring Yellow	100
66-67	Yellow	101
68-69	Light Amber	102
70-71	Straw	103
72-73	Deep Amber	104
74-75	Primary Red	106
76-77	Light Rose	107
78-79	English Rose	108
80-81	Light Salmon	109
82-83	Middle Rose	110
84-85	Dark Pink	111
86-87	Magenta	113
88-89	Peacock Blue	115
90-91	Steel Blue	117
92-93	Light Blue	118
94-95	Deep Blue	120
96-97	LEE Green	121
98-99	Fern Green	122
100-101	Dark Green	124
102-103	Smokey Pink	127
104-105	Bright Pink	128
106-107	Marine Blue	131
108-109	Golden Amber	134
110-111	Deep Golden Amber	135
112-113	Pale Lavender	136
114-115	Special Lavender	137
116-117	Pale Green	138
118-119	Summer Blue	140
120-121	Pale Violet	142
122-123	Pale Navy Blue	143
124-125	No Color Blue	144
126-127	Apricot	147
128-129	Bright Rose	148
130-131	Gold Tint	151
132-133	Pale Gold	152
134-135	Pale Salmon	153
136-137	Pale Rose	154
138-139	Chocolate	156
140-141	Pink	157
142-143	No Color Straw	159
144-145	Slate Blue	161
146-147	Bastard Amber	162
148-149	Flame Red	164
150-151	Daylight Blue	165
152-153	Lilac Tint	169
154-155	Deep Lavender	170
156-157	Dark Steel Blue	174
158-159	Loving Amber	176
160-161	Dark Lavender	180
162-163	Light Red	182
164-165	Flesh Pink	192
166-167	Surprise Pink	194
168-169	Zenith Blue	195
170-171	True Blue	196
172-173	Alice Blue	197
174-175	Palace Blue	198
176-177	Regal Blue	199

DMX channel	600 (in total 9)	
	Name	Model
0-1	Arctic White	600
2-3	Silver	601
4-5	Platinum	602
6-7	Moonlight White	603
8-9	Full CT 85	604
10-11	Industry Sodium	650
12-13	HI Sodium	651
14-15	Urban Sodium	652
16-17	LO Sodium	653

DMX channel	COS. (in total 18)	
	Name	Model
0-1	Cosmetic Peach	184
2-3	Cosmetic Silver Rose	186
4-5	Cosmetic Rouge	187
6-7	Cosmetic Highlight	188
8-9	Cosmetic Silver Moss	189
10-11	Cosmetic Aqua Blue	191
12-13	Lily Frost	705
14-15	Shanklin Frost	717
16-17	Half Shanklin Frost	718
18-19	Durham Daylight Frost	720
20-21	Hampshire Rose	749
22-23	Durham Frost	750
24-25	Soft Amber Key 1	774
26-27	Soft Amber Key 2	775
28-29	Moroccan Frost	791
30-31	Blue Diffusion	217
32-33	Blue Frost	221
34-35	Daylight Blue frost	224

DMX channel	700 (in total 41)	
	Name	Model
0-1	Perfect Lavender	700
2-3	Provence	701
4-5	Special Pale Lavender	702
6-7	Cold Lavender	703
8-9	Lily	704
10-11	King Fals Lavender	706
12-13	Cool Lavender	708
14-15	Electric Lilac	709
16-17	Spir Special Blue	710
18-19	Cold Blue	711
20-21	Bedford Blue	712
22-23	Elysian Blue	714
24-25	Cabana Blue	715
26-27	Mikkel Blue	716
28-29	Colour Wash Blue	719
30-31	Berry Blue	721
32-33	Virgin Blue	723
34-35	Ocean Blue	724
36-37	Old Steel Blue	725
38-39	Steel Green	728
40-41	Liberty Green	730
42-43	Dirty Ice	731
44-45	Damp Squib	733
46-47	JAS Green	738
48-49	Bram Brown	742
50-51	Dirty White	744
52-53	Brown	746
54-55	Easy White	747
56-57	Seedy Pink	748
58-59	Wheat	763
60-61	Sun Colour Straw	764
62-63	LEE Yellow	765
64-65	Cardbox Amber	773
66-67	Nectarine	776
68-69	Millenium Gold	778
70-71	Bastard Pink	779
72-73	Terry Red	781
74-75	Blood Red	789
76-77	Moroccan Pink	790
78-79	Pretty n'Pink	794
80-81	Magical Magenta	795

X-Y 16Bit Mode

DMX channel	Function	Parameter	DMX value 16Bit		Actual value 16Bit	
			Starting	Ending	Starting	Ending
16Bit	X-Y		Starting	Ending	Starting	Ending
1-2		Brightness	0	65535	0.0%	100.0%
3-4		X	0	65535	0	0.85
5-6		Y	0	65535	0	0.85

Extend DMX Channels: The DMX mode will add extended channels when this function is turned on, as shown in the following table. Turning on the extend DMX channels will take up more channels, and this setting is off by default.

DMX channel	Function	Parameter	DMX value 16Bit		Actual value 16Bit
7	X-Y	Mode	0	9	Normal
			10	19	Highspeed
			20	29	Low End
			30	255	Preset
8		Frequency	0	9	1
			10	19	2
			20	29	3
			30	39	4
			40	49	5
			50	59	6
			60	69	7
			70	79	8
			80	89	9
			90	99	10
9	Smoothing	100	109	11	
		110	255	Preset	
		0	9	Default	
		10	19	Smooth	
		20	29	Off	
		30	255	Preset	

CCT + RGBW Engine 8Bit Mode

DMX channel	Function	Parameter	DMX value 8Bit		Actual value 8Bit	
			Starting	Ending	Starting	Ending
8Bit			Starting	Ending	Starting	Ending
1	CCT+RGBW Engine 1	Brightness	0	255	0.0%	100.0%
2		CCT	0	255	1800K	10000K
3		GM	0	255	-100%	100%
4		Dissolve	0	255	0	100
5		R	0	255	0.0%	100.0%
6		G	0	255	0.0%	100.0%
7		B	0	255	0.0%	100.0%
8		W	0	255	0.0%	100.0%
9	CCT+RGBW Engine 2	Brightness	0	255	0.0%	100.0%
10		CCT	0	255	1800K	10000K
11		GM	0	255	-100%	100%
12		Dissolve	0	255	0	100
13		R	0	255	0.0%	100.0%
14		G	0	255	0.0%	100.0%
15		B	0	255	0.0%	100.0%
16		W	0	255	0.0%	100.0%
17	CCT+RGBW Engine 3	Brightness	0	255	0.0%	100.0%
18		CCT	0	255	1800K	10000K
19		GM	0	255	-100%	100%
20		Dissolve	0	255	0	100
21		R	0	255	0.0%	100.0%
22		G	0	255	0.0%	100.0%
23		B	0	255	0.0%	100.0%
24		W	0	255	0.0%	100.0%
25	CCT+RGBW Engine 4	Brightness	0	255	0.0%	100.0%
26		CCT	0	255	1800K	10000K
27		GM	0	255	-100%	100%
28		Dissolve	0	255	0	100
29		R	0	255	0.0%	100.0%
30		G	0	255	0.0%	100.0%
31		B	0	255	0.0%	100.0%
32		W	0	255	0.0%	100.0%

Extend DMX Channels: The DMX mode will add extended channels when this function is turned on, as shown in the following table. Turning on the extend DMX channels will take up more channels, and this setting is off by default.

DMX channel	Function	Parameter	DMX value 8Bit		Actual value 8Bit
33		Mode	0	9	Normal
			10	19	Highspeed
			20	29	Low End
			30	255	Preset
34	CCT+RGBW Engine	Frequency	0	9	1
			10	19	2
			20	29	3
			30	39	4
			40	49	5
			50	59	6
			60	69	7
			70	79	8
			80	89	9
			90	99	10
			100	109	11
			110	255	Preset
35		Smoothing	0	9	Default
			10	19	Smooth
			20	29	Off
			30	255	Preset

HSI Engine 8Bit Mode

DMX channel	Function	Parameter	DMX value 8Bit		Actual value 8Bit	
			Starting	Ending	Starting	Ending
8Bit						
1	HSI Engine 1	Brightness	0	255	0.0%	100.0%
2		Hue	0	255	0	360
3		Saturation	0	255	0	100
4	HSI Engine 2	Brightness	0	255	0.0%	100.0%
5		Hue	0	255	0	360
6		Saturation	0	255	0	100
7	HSI Engine 3	Brightness	0	255	0.0%	100.0%
8		Hue	0	255	0	360
9		Saturation	0	255	0	100
10	HSI Engine 4	Brightness	0	255	0.0%	100.0%
11		Hue	0	255	0	360
12		Saturation	0	255	0	100

Extend DMX Channels: The DMX mode will add extended channels when this function is turned on, as shown in the following table. Turning on the extend DMX channels will take up more channels, and this setting is off by default.

DMX channel	Function	Parameter	DMX value 16Bit		Actual value 16Bit
13		Mode	0	9	Normal
			10	19	Highspeed
			20	29	Low End
			30	255	Preset
14	HSI Engine	Frequency	0	9	1
			10	19	2
			20	29	3
			30	39	4
			40	49	5
			50	59	6
			60	69	7
			70	79	8
			80	89	9
			90	99	10
			100	109	11
			110	255	Preset
15		Smoothing	0	9	Default
			10	19	Smooth
			20	29	Off
			30	255	Preset

FX 8Bit Mode & FX 16Bit Mode

DMX channel		Function	Parameter	DMX value 8 Bit		Actual value 8Bit		DMX value 16Bit		Actual value 16Bit		
8Bit	16Bit			Starting	Ending	Starting	Ending	Starting	Ending	Starting	Ending	
1	1-2	FX	Effect type	Brightness	0	255	0.0%	100.0%	0	65535	0.0%	100.0%
2	3			0	9	FX Off		0	9	FX Off		
				10	19	Flash		10	19	Flash		
				20	29	Lightning		20	29	Lightning		
				30	39	Cloudy		30	39	Cloudy		
				40	49	Broken Bulb		40	49	Broken Bulb		
				50	59	TV		50	59	TV		
				60	69	Candle		60	69	Candle		
				70	79	Fire		70	79	Fire		
				80	89	Firework		80	89	Firework		
				90	99	Explosion		90	99	Explosion		
				100	109	Welding		100	109	Welding		
				110	119	Police Car		110	119	Police Car		
				120	129	SOS		120	129	SOS		
				130	139	RGB Cycle		140	139	RGB Cycle		
				140	149	Party		150	149	Party		
				150	159	Rainbow		160	159	Rainbow		
				160	169	Pixel Candle		170	169	Pixel Candle		
		170	179	Pixel Fire		180	179	Pixel Fire				
3	4	Flash	Type	0	255	CCT(0-127)	HSI(128-255)	0	255	CCT(0-127)	HSI(128-255)	
4	5-6		CCT/Hue	0	255	1800K/0	10000K/360	0	65535	1800K/0	10000K/360	
5	7-8		Speed	0	255	0	100	0	65535	0	100	
6	9-10	Mode	0	255	0 Camera flash	1 Flash bulb	0	255	0 Camera flash	1 Flash bulb		
3	4-5	Lightning	CCT	0	255	2800K	6500K	0	65535	2800K	6500K	
4	6-7		Frequency	0	255	0	20	0	65535	0	20	
5	8-9		Times	0	255	0	10	0	65535	0	10	
3	4-5	Cloudy	Ratio	0	255	10%	90%	0	65535	10%	90%	
4	6-7		Speed	0	255	0	100	0	65535	0	100	
3	4-5	Broken Bulb	Type	0	255	CCT(0-127)	HSI(128-255)	0	255	CCT(0-127)	HSI(128-255)	
4	5-6		CCT/Hue	0	255	1800K/0	10000K/360	0	65535	1800K/0	10000K/360	
5	7-8		Speed	0	255	0	100	0	65535	0	100	
3	4-5	TV	Type	0	255	CCT(0-127)	HSI(128-255)	0	255	CCT(0-127)	HSI(128-255)	
4	5-6		Speed	0	255	0	100	0	65535	0	100	
3	4-5	Candle	Speed	0	255	0	100	0	65535	0	100	
3	4-5		Speed	0	255	0	100	0	65535	0	100	
3	4-5	Firework	Speed	0	255	0	100	0	65535	0	100	
4	6-7		Embers	0	255	0	100	0	65535	0	100	
3	4-5	Explosion	Type	0	255	CCT(0-127)	HSI(128-255)	0	255	CCT(0-127)	HSI(128-255)	
4	6-7		CCT/Hue	0	255	1800K/0	10000K/360	0	65535	1800K/0	10000K/360	
5	8-9		Speed	0	255	0	100	0	65535	0	100	
6	10-11		Embers	0	255	0	100	0	65535	0	100	
3	4-5	Welding	Type	0	255	CCT(0-127)	HSI(128-255)	0	255	CCT(0-127)	HSI(128-255)	
4	6-7		CCT/Hue	0	255	1800K/0	10000K/360	0	65535	1800K/0	10000K/360	
5	8-9		Speed	0	255	0	100	0	65535	0	100	
3	4-5	SOS	Type	0	255	CCT(0-127)	HSI(128-255)	0	255	CCT(0-127)	HSI(128-255)	
4	6-7		CCT/Hue	0	255	1800K/0	10000K/360	0	65535	1800K/0	10000K/360	
3	4	Police Car	Color	0	255	0	7	0	255	0	7	
4	5		Mode	0	255	0	4	0	255	0	4	
3	4-5	RGB Cycle	Saturation	0	255	0	100	0	65535	0	100	
4	6		Speed	0	255	1	100	0	65535	1	100	
3	4-5	Party	Saturation	0	255	0	100	0	65535	0	100	
4	6		Speed	0	255	1	100	0	65535	1	100	
3	4	Pixel Candle	Tone	0-84		Warm		0-84		Warm		
				85-169		Neutral		85-169		Neutral		
				170-255		Cool		170-255		Cool		
4	5-6	Pixel Fire	Speed	0	255	1	100	0	65535	1	100	
3	4			Tone	0-84		Warm		0-84		Warm	
					85-169		Neutral		85-169		Neutral	
					170-255		Cool		170-255		Cool	
4	6-7			0	255	1	100	0	65535	1	100	

Extend DMX Channels: The DMX mode will add extended channels when this function is turned on, as shown in the following table. Turning on the extend DMX channels will take up more channels, and this setting is off by default.

DMX channel		Parameter	DMX value 8Bit		Actual value 8Bit	DMX value 16Bit		Actual value 16Bit
7	12	Mode	0	9	Normal	0	9	Normal
			10	19	Highspeed	10	19	Highspeed
			20	29	Low End	20	29	Low End
			30	255	Preset	30	255	Preset
8	13	Frequency	0	9	1	0	9	1
			10	19	2	10	19	2
			20	29	3	20	29	3
			30	39	4	30	39	4
			40	49	5	40	49	5
			50	59	6	50	59	6
			60	69	7	60	69	7
			70	79	8	70	79	8
			80	89	9	80	89	9
			90	99	10	90	99	10
			100	109	11	100	109	11
						110	255	Preset
9	14	Smoothing	0	9	Default	0	9	Default
			10	19	Smooth	10	19	Smooth
			20	29	Off	20	29	Off
			30	255	Preset	30	255	Preset

Calculation Formula:

Brightness

8Bit

$$\text{DMX value} = \frac{\text{Brightness value}}{0.3922}$$

$$\text{Brightness value} = \text{DMX value} \times 0.3922$$

16Bit

$$\text{DMX value} = \frac{\text{Brightness value}}{0.001526}$$

$$\text{Brightness value} = \text{DMX value} \times 0.001526$$

CCT

8Bit

$$\text{DMX value} = \frac{\text{CCT value} - 1800}{32.1568}$$

$$\text{CCT value} = \text{DMX value} \times 32.1568 + 1800$$

16Bit

$$\text{DMX value} = \frac{\text{CCT value} - 1800}{0.1251}$$

$$\text{CCT value} = \text{DMX value} \times 0.1251 + 1800$$