

705-SL1520-03

Warning

Operating frequency:2412.99MHz – 2464.49MHz (only receive)

Declaration of Conformity

GODOX Photo Equipment Co.,Ltd. hereby declares that this equipment are in compliance with the essential requirements and other relevant provisions of Directive 2014/53/EU. In accordance with Article 10(2) and Article 10(10), this product is allowed to be used in all EU member states.For more information of DoC, Please click this web link:

https://www.godox.com/DOC/Godox_SL200II_SL150II_DOC.pdf

The device complies with RF specifications when the device used at 0mm from your body.

合格证
QC PASS

深圳市神牛摄影器材有限公司

地址: 深圳市宝安区福海街道塘尾社区耀川工业区厂房2栋

电话: 0755-29609320(8062) 传真: 0755-25723423 邮箱: godox@godox.com

GODOX Photo Equipment Co., Ltd.

Add: Building 2, Yaochuan Industrial Zone, Tangwei Community, Fuhai Street, Bao'an District, Shenzhen 518103, China Tel: +86-755-29609320(8062) Fax: +86-755-25723423

E-mail: godox@godox.com

godox.com

Made in China



Godox

SL系列摄影灯

SL Series LED Video Light

SL200II SL150II



使用手册
Instruction Manual

前言

感谢您购买神牛产品!

SL系列摄影灯SL150II/SL200II在原有SL系列摄影灯的基础上增加了8种特效模式,可打造更多创意拍摄。功率强劲,光效柔和,适用范围广泛。

主要特点:

- 8种FX特效模式,模拟各种拍摄场景,轻松实现创意光效
- 静音模式:无风扇,零噪音,无干扰
- 强光模式:功率可达最大
- 内置神牛2.4G无线X系统,可无线调节LED灯
- 光源稳定,0%-100%精确调节亮度
- 16组32频道分组遥控
- U型支架设计,可吊装,方便调节各种亮度
- 保荣卡口,支持安装各类光效附件
- LCD屏清晰显示
- 良好的散热性能

警告

- ⚠ 请保持干燥:请勿用湿手接触产品,亦不可将产品浸入水中或暴露于雨中。
- ⚠ 请勿私自拆卸产品,如产品出现故障须由本公司或授权的维修人员进行检查维修。
- ⚠ 请勿让儿童接触本产品。
- ⚠ 本产品不能防水,在雨天及潮湿环境下请注意防水。
- ⚠ 请勿放置在超过40摄氏度的高温环境中。
- ⚠ 请勿在化学品、可燃性气体或其他特殊物质附近使用LED灯。在这些场合下,请注意相关警告标识。

部件名称

灯体

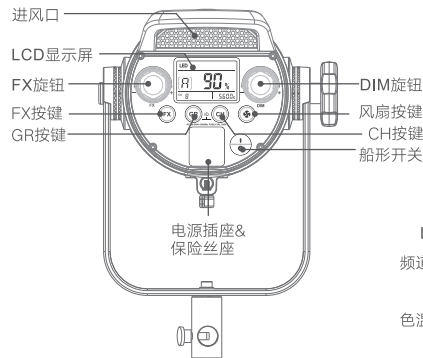
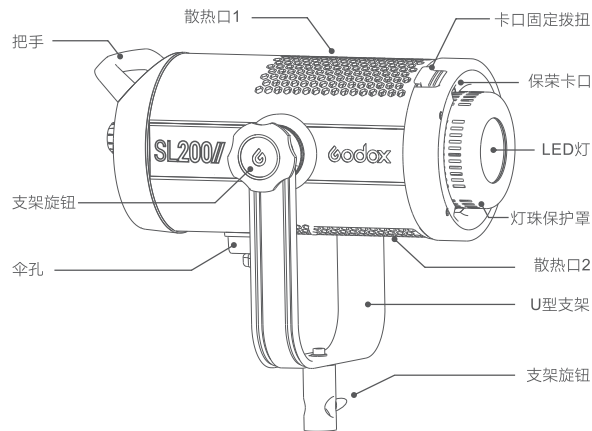

部件名称

LCD液晶显示屏

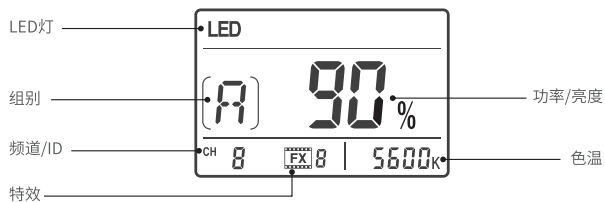

标配物品



可选购附件

可搭配本公司以下摄影附件使用, 以获得最佳的拍摄效果和使用体验:
RC-A6遥控器、逆变器、柔光箱、反光伞、灯架、蜂巢、雷达罩、束光筒等。

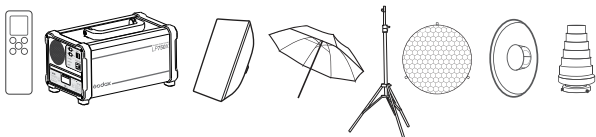

接通电源

通过电源线接通交流电源与LED灯, 拨动LED灯上的电源开关至ON, 即可开机。

操作说明

一、模式选择

- 1.1 LED静音模式:** 不打开风扇和特效模式时为静音模式, 静音模式零噪音, 无干扰。
- 1.2 LED特效模式:** 短按FX按键进入或退出特效模式。进入特效模式时显示屏显示FX, 旋转FX旋钮选择特效场景。有8种FX特效模式, 模拟各种拍摄场景, 轻松实现创意光效。

显示	Fx1	Fx2	Fx3	Fx4	Fx5	Fx6	Fx7	Fx8
场景	Flash1	Flash2	Flash3	Storm1	Storm2	Storm3	TV	坏灯泡

- 1.3 LED强光模式:** 打开风扇进入LED灯强光模式, 强光模式时功率达到最大。

二、设置

亮度调节

旋转DIM旋钮调节亮度, 亮度调节范围0%-100%, LCD显示屏将准确显示所设置的亮度。

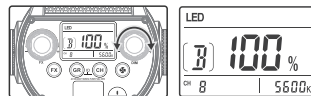

组别GR、频道CH、ID设置

组别GR设置: 短按GR按键, 选择组别, 组别选择范围: A、B、C、D、E、F、0-9。

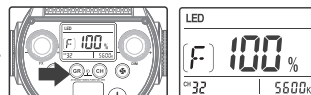

频道CH设置: 短按CH按键, 选择通道CH, 通道选择范围: 1-32。

ID设置: 同时长按GR和CH键进入ID设置界面, 旋转DIM旋钮选择ID, ID选择范围: 0F, 01-99。

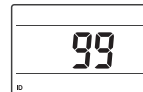

三、无线控制(遥控器另购)

SL系列摄影灯SL150II/SL200II具备无线接收功能,使用遥控器RC-A6,可同时分别控制多个LED灯。

32个频道,100个无线ID,抗干扰强。

注:使用前请把LED灯和RC-A6遥控器的频道、组别和ID调至一致。

遥控器频道/组别调整

- 在常态时,按CH/GR按钮,此时组别闪烁,按"- "+"按钮可选择组别(A~F,0~9)。
- 在常态时,按CH/GR按钮2次,此时频道闪烁,按"- "+"按钮可选择频道(1~32)。

遥控器ID调整

- 在常态时,双击CH/GR按钮,按"- "+"按钮可选择ID号(ID号为OFF,0-99)。

遥控器亮度参数调节

- 在常态时,按"- "+"按钮可对亮度调整。

遥控器色温参数调节(此LED灯色温为不可调)

- 在常态时,按SET按钮,此时色温值闪烁,按"- "+"按钮可对色温调整。

遥控器复位:同时按住"- "+"按钮即可复位。

色温调节范围设定:

出厂时遥控器的色温调节范围为2500-10000K。

为方便客户使用遥控器还设置了色温调节范围设定功能:在关机状态下按住SET按钮开机进入色温调节界面,按CH/GR按钮切换最低色温和最高色温设置,按"- "、" +"按钮选择色温值,按SET键确定选择的色温。

注:LED灯在开机状态下才可以接收无线信号。

产品参数

摄影灯	SL150II	SL200II
供电	AC100V-240V(50/60HZ)	
最大功率	150W	200W
色温	5600±200K	
100%光照度(LUX, 1米距离)	≈58000	≈74000
CRI ≈	96	
TLCI ≈	97	
常亮模式调光范围	0%-100%	
工作环境温度	-10°C~40°C	
频道	32个	
组别	16组(A、B、C、D、E、F,0-9)	
产品尺寸(不含反光罩)	34x20x16cm	36.7x20x16cm
净量	2.95Kg	3.33Kg

*设计和规格如有变更,恕不另行通知。

Foreword

Thank you for purchasing this Godox Product!

With 8 special effects modes, strong power, soft illumination and abundant functions, SL Series LED Video Light SL150II/SL200II can achieve creative shooting easily.

Main Features:

- With 8 FX special effects mode to simulate various of shooting scene.
- Silent mode: fanless, without noises and interference.
- Strong power mode: the power can be up to the maximum value.
- Built-in Godox 2.4G wireless X system & wirelessly adjust parameters.
- With stable light source and 0% to 100% precise light adjustment.
- With 16 groups and 32 channels wireless control.
- With U-type bracket to adjust different angles easily.
- Bowens-mount enables to install various of accessories.
- Clear LCD display.
- Excellent heat dissipation.

Warning

- ▲ Always keep this product dry. Do not use in rain or in damp conditions.
- ▲ Do not disassemble. Should repairs become necessary, this product must be sent to an authorized maintenance center.
- ▲ Keep out of reach of children.
- ▲ As this product do not have waterproof function, please take measures of waterproof in rainy or damp environment.
- ▲ Do not use the product in the presence of flammable gases, chemicals and other similar materials.
- ▲ As this product has built-in lithium battery, do not disassemble, impact, squeeze or put it into fire. If serious bulge occurs, please do not use. Do not use or store the product if the ambient temperature reads over 40°C. Please charge the product with specialized charger and correctly operate it within the defined voltage and working temperate according to the instruction manual.

Body

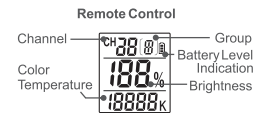
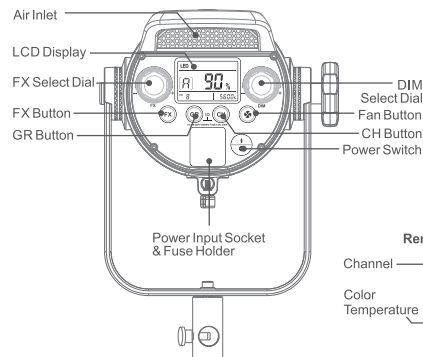
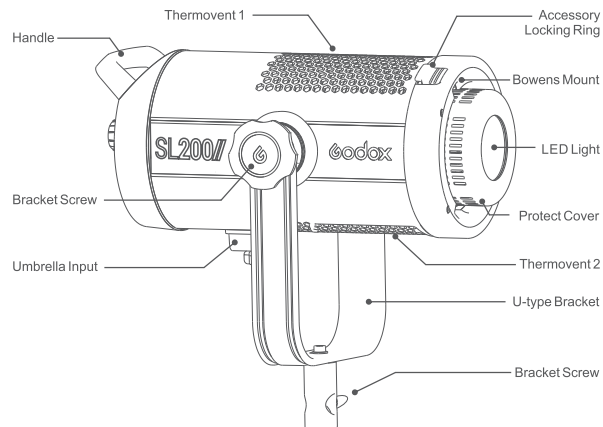

LCD Panel

LCD Panel

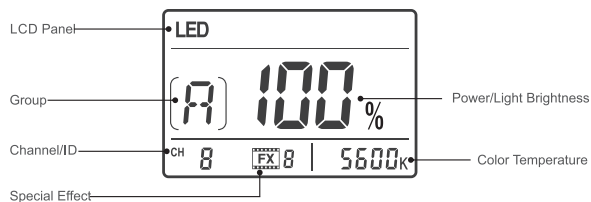

Included Items

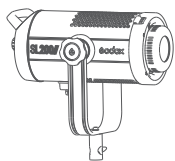

LED video light *1



Reflector for Bowens mount LED light *1



Lamp cover *1



Power cord *1

Separately Sold Accessories

The product can be used in combination with the following accessories sold separately, so as to achieve best photography effects: RC-A6 remote control, Power Inverter, Softbox, Photographic Umbrella, Light Stand, Barndoor, Snoot, etc.

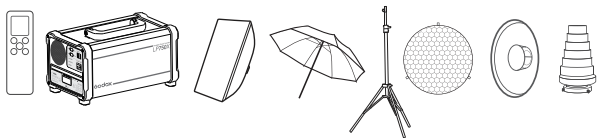

Power Connection

Use the power cord to connect the LED light to an AC power source and turn on the power switch.

Operation

Setting

Mode Selection

1.1 LED silent mode: in this mode, the fan and special effects are turned off. There is no noises and interference in this mode.

1.2 LED special effects modes: Short press the FX button to enter or exit the special effects. When entering the FX modes, FX icon will be displayed on the LCD panel. Then, turn the FX select dial to choose one mode from the 8 special effects modes to achieve creative shooting.

Display	Fx1	Fx2	Fx3	Fx4	Fx5	Fx6	Fx7	Fx8
Scene	Flash1	Flash2	Flash3	Storm1	Storm2	Storm3	TV	Broken bulb

1.3 LED strong power mode: turn on the fan to enter LED strong power mode and the power will up to the maximum value in this mode.

Light Brightness Adjustment

In LED mode, the light brightness of LED light can be adjusted by turning the DMX select dial from 0% to 100%. And the light brightness will be clearly displayed on the LCD Panel.

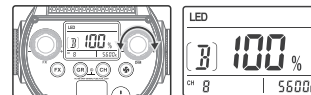

Group GR, Channel CH and ID Setting

GR Setting: Short press GR button to choose group from A, B, C, D, E, F and 0 to 9.

CH Setting: Short press CH button to choose channel from 1 to 32.

ID Setting: Long press GR and CH button to enter ID setting interface. Then, turn the DIM select dial to choose ID from OF and 01 to 99.

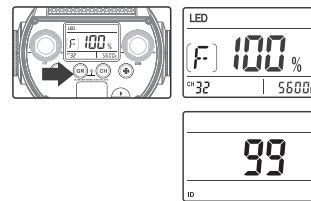

Wireless Control

With 2.4G wireless system, SL Series SL150II/SL200II have receive and control function. Up to multiple groups of LED lights can be controlled. 32 channels and 100 wireless IDs are available with strong anti-interference capability. Please set the channels, groups and IDs of LED light to the same as those of RC-A6 remote control before usage.

Adjusting Channel/Group with the Remote Control

- Press the CH/GR button and the group icon blinks.
Press the "-" "+" button to choose a group (A to F, 0 to 9).
- Press the CH/GR button twice and the channel icon blinks.
Press the "-" "+" button to choose a channel (1 to 32).

Adjusting ID with the Remote Control

- Double click the CH/GR button and press the "-" "+" button to choose ID from OFF or 0 to 99.

Adjusting Light Brightness with the Remote Control

- Press the "-" "+" button to adjust the light brightness.

Adjusting Color Temperature with the Remote Control (The color temperature value of this LED light cannot be adjusted)

- Press the SET button of the remote control and the color temperature icon blinks.

Press the "-" "+" button
to adjust the color temperature.

Remote control reset: press down "-" and "+" button simultaneously to reset.

**Note: The wireless signal can be received only when the controller of LED light is powered on.
Remote control is available separately.**

Setting color temperature range

The factory setting of remote control's color temperature range is 2500-10000K.

In order to use remote control conveniently, color temperature range settings are added: when the remote control is off, hold down the SET button and turn it on to enter color temperature adjusting interface. Press CH/GR button to switch the lowest and highest color temperature value and press "-" or "+" button to change the value. Press the SET button to confirm it.

Technical Data

LED Video Light	SL150II	SL200II
Power Supply	AC100V-240V (50/60Hz)	
Max Power	150W	200W
Color Temperature	5600±200K	
100% Light Brightness(LUX,1M)	≈58000	≈74000
CRI ≈	96	
TLCI ≈	97	
Light Brightness Range	10%-100%	
Operation Temperature	-10°C ~ 40°C	
Channel	32	
Group	16(A, B, C, D, E, F, 0-9)	
Dimension (not included a standard reflector)	34x20x16cm	36.7x20x16cm
Net Weight	2.95Kg	3.33Kg

FCC Statement

This device complies with part 15 of the FCC Rules. Operation is subject to the following two conditions: (1) This device may not cause harmful interference, and (2) this device must accept any interference received, including interference that may cause undesired operation.

Note: This equipment has been tested and found to comply with the limits for a Class B digital device, pursuant to part 15 of the FCC Rules. These limits are designed to provide reasonable protection against harmful interference in a residential installation. This equipment generates uses and can radiate radio frequency energy and, if not installed and used in accordance with the instructions, may cause harmful interference to radio communications. However, there is no guarantee that interference will not occur in a particular installation. If this equipment does cause harmful interference to radio or television reception, which can be determined by turning the equipment off and on, the user is encouraged to try to correct the interference by one or more of the following measures:

- Reorient or relocate the receiving antenna.
- Increase the separation between the equipment and receiver.
- Connect the equipment into an outlet on a circuit different from that to which the receiver is connected.
- Consult the dealer or an experienced radio/TV technician for help.

产品保修

尊敬的用户，本保修卡是申请保修服务的重要凭证，请您配合销售商填写并妥善保管，谢谢！

产品信息	型号	产品条码
用户信息	姓名	联系电话
	通信地址	
销售商信息	名称	
	联系电话	
	通信地址	
	销售日期	
备注		

注：此表应由销售商盖章确认。

适用产品

本文件适用于相关《产品保修信息》(见后面说明)所列产品，其他非属此范围的产品或部件(如促销品、赠品及其他出厂后附加的部件等)不在此保修承诺内。

保修期

产品及部件的相应保修期按相关的《产品保修信息》执行。保修期自产品首次购买日起算，购买日以购买产品时保修卡登记日期为准。

如何获得保修服务

要保修服务，您可直接与产品销售商或授权服务机构联系，也可拨打神牛产品售后服务电话，与我们联系，由我们的服务人员为您安排服务。申请保修时，您应提供有效的保修卡作为保修凭证，方可获得保修。如您不能提供有效的保修卡，则在我们可确认产品或部件属于保修范围的情况下，也可以为您提供保修，但这不作为我们的义务。

不适用保修的情况

如产品存在下列情况，本文件项下的保证和服务将不适用 ①产品或部件超过相应保修期；②错误或不适当使用、维护或保管导致的故障或损坏，如：不当搬运；非按产品合理预期用途使用；不当插拔外接设备；跌落或外力挤压；接触或暴露于不适当温度、溶剂、酸碱、水浸或潮湿环境；③由非神牛授权机构或人员安装、修理、更改、添加或拆卸造成的故障或损坏；④产品或部件原有识别信息被修改变更或删除；⑤无有效保修卡；⑥使用非合法授权、非标准或非公开发行的软件造成的故障或损坏；⑦因不可抗力或意外事件造成的故障或损坏；⑧其他非因产品本身质量问题导致的故障或损坏。遇上述情况，您应向相关责任方寻求解决，神牛对此不承担任何责任。因非在保修期或保修范围内的部件、附件或软件导致产品不能正常使用的，不是保修范围内的故障。产品使用过程中正常的脱色、磨损和消耗，不是保修范围内的故障。

产品保修和服务支持信息

产品的保修期和服务类型按以下《产品保修信息》执行：

产品类别	选件名称	保修期(月)	保修服务类型
部件	电路板	12	客户送修
	电池	3	客户送修
	充电器、电源线，同步线等带电性能的部件。	12	客户送修
其他	如闪光管、造型灯泡、外壳、保护罩、锁紧装置、包装等。	无	无保修

神牛产品售后服务电话 0755-29609320-8062

Warranty

Dear customers, as this warranty card is an important certificate to apply for our maintenance service, please fill in the following form in coordination with the seller and safe-keep it. Thank you!

Product Information	Model	Product Code Number
Customer Information	Name	Contact Number
	Address	
Seller Information	Name	
	Contact Number	
	Address	
	Date of Sale	
Note:		

Note: This form shall be sealed by the seller.

Applicable Products

The document applies to the products listed on the **Product Maintenance Information** (see below for further information). Other products or accessories (e.g. promotional items, giveaways and additional accessories attached, etc.) are not included in this warranty scope.

Warranty Period

The warranty period of products and accessories is implemented according to the relevant Product Maintenance Information. The warranty period is calculated from the day(purchase date) when the product is bought for the first time, And the purchase date is considered as the date registered on the warranty card when buying the product.

How to Get the Maintenance Service

If maintenance service is needed, you can directly contact the product distributor or authorized service institutions. You can also contact the Godox after-sale service call and we will offer you service. When applying for maintenance service, you should provide valid warranty card. If you cannot provide valid warranty card, we may offer you maintenance service once confirmed that the product or accessory is involved in the maintenance scope, but that shall not be considered as our obligation.

Inapplicable Cases

The guarantee and service offered by this document are not applicable in the following cases: ①. The product or accessory has expired its warranty period; ②. Breakage or damage caused by inappropriate usage, maintenance or preservation, such as improper packing, improper usage, improper plugging in/out external equipment, falling off or squeezing by external force, contacting or exposing to the improper temperature, solvent, acid, base, flooding and damp environments, etc; ③. Breakage or damage caused by non-authorized institution or staff in the process of installation, maintenance, alternation, addition and detachment; ④. The original identifying information of product or accessory is modified, alternated, or removed; ⑤. No valid warranty card; ⑥. Breakage or damage caused by using illegally authorized, nonstandard or non-public released software; ⑦. Breakage or damage caused by force majeure or accident; ⑧. Breakage or damage that could not be attributed to the product itself. Once met these situations above, you should seek solutions from the related responsible parties and Godox assumes no responsibility. The damage caused by parts, accessories and software that beyond the warranty period or scope is not included in our maintenance scope. The normal discoloration, abrasion and consumption are not the breakage within the maintenance scope.

Maintenance and Service Support Information

The warranty period and service types of products are implemented according to the following **Product Maintenance Information**:

Product Type	Name	Maintenance Period(month)	Warranty Service Type
Parts	Circuit Board	12	Customer sends the product to designated site
	Battery	3	Customer sends the product to designated site
	Electrical parts e.g.battery charger, power cord, sync cable, etc.	12	Customer sends the product to designated site
Other Items	Flash tube, modeling lamp, lamp body, lamp cover, lockingdevice, package, etc.	No	Without warranty

Godox After-sale Service Call 0755-29609320-8062